

Dunlop DSL3 Scissor Lift

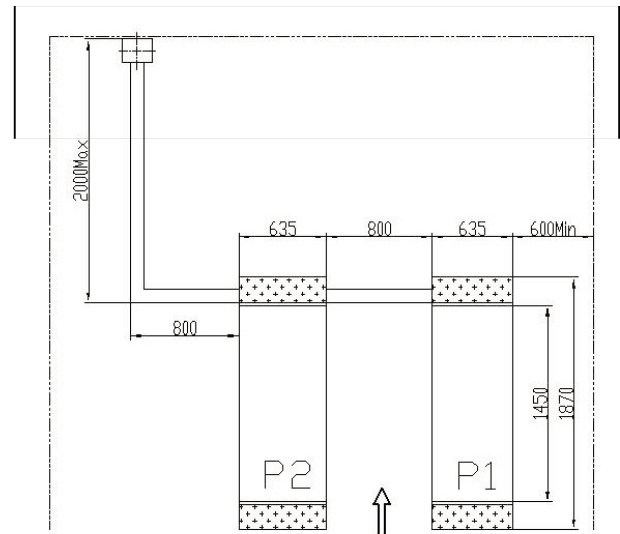

- 3 Tonnes Capacity
- Hydraulic synchronisation.
- CE Approved
- Min. lift Height = 105mm
- Choice of 415v 3 phase or single phase 240v
- Twin hydraulic cylinders each side.
- Pneumatic safety locks
- Max. lift Height = 1840mm
- Delivery and installation included.
- 4 x lifting blocks included

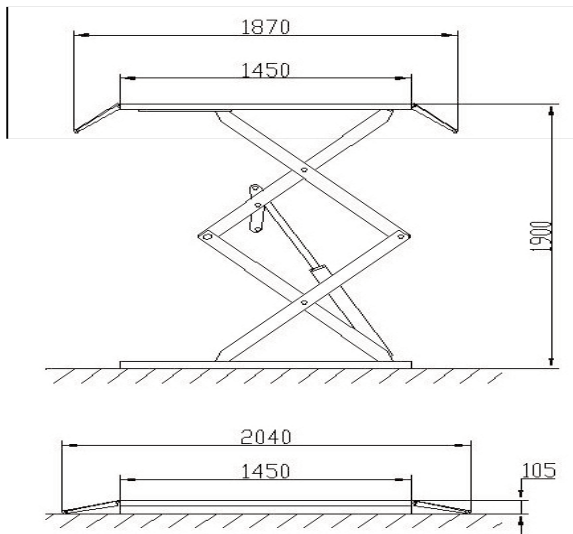

Control box can be left or right